

TORO C Range			TORO C-306	TORO C-305	TORO C-303	TORO C-304/C	TORO C-302/C	TORO C-301/C
Number of sections			5	4	3	5	4	3
Maximum load			300 kg 661 lb	320 kg 705 lb	350 kg 772 lb	320 kg 705 lb	330 kg 728 lb	350 kg 772 lb
Weight			197 kg 434 lb	179 kg 395 lb	161 kg 355 lb	182 kg 401 lb	169 kg 373 lb	152 kg 335 lb
STOWED								
Height	A		198 cm 6 ft 6 in	198 cm 6 ft 6 in	198 cm 6 ft 6 in	160 cm 5 ft 3 in	160 cm 5 ft 3 in	160 cm 5 ft 3 in
Length	B		95 cm 3 ft 1.5 in	95 cm 3 ft 1.5 in	95 cm 3 ft 1.5 in	95 cm 3 ft 1.5 in	95 cm 3 ft 1.5 in	95 cm 3 ft 1.5 in
Width	C		66 cm 2 ft 2 in	66 cm 2 ft 2 in	66 cm 2 ft 2 in	66 cm 2 ft 2 in	66 cm 2 ft 2 in	66 cm 2 ft 2 in
WORKING MEASUREMENTS								
Maximum height	Forks up	D ₁	800 cm 26 ft 3 in	650 cm 21 ft 4 in	500 cm 16 ft 5 in	600 cm 19 ft 8 in	500 cm 16 ft 5 in	385 cm 12 ft 7.5 in
	Forks down	D ₂	760 cm 24 ft 11 in	610 cm 20 ft	460 cm 15 ft 1 in	560 cm 18 ft 4.5 in	460 cm 15 ft 1 in	345 cm 11 ft 4 in
Length	Front legs	E ₁	192 cm 6 ft 3.5 in	192 cm 6 ft 3.5 in	192 cm 6 ft 3.5 in	192 cm 6 ft 3.5 in	192 cm 6 ft 3.5 in	192 cm 6 ft 3.5 in
	Back legs	E ₂	183 cm 6 ft	183 cm 6 ft	183 cm 6 ft	183 cm 6 ft	183 cm 6 ft	183 cm 6 ft
Width		F	66 cm 2 ft 2 in	66 cm 2 ft 2 in	66 cm 2 ft 2 in	66 cm 2 ft 2 in	66 cm 2 ft 2 in	66 cm 2 ft 2 in
Leg height		G	28 cm 11 in	28 cm 11 in	28 cm 11 in	28 cm 11 in	28 cm 11 in	28 cm 11 in
Width w/ stabilisers unfolded		H	147 cm 4 ft 10 in	147 cm 4 ft 10 in	147 cm 4 ft 10 in	147 cm 4 ft 10 in	147 cm 4 ft 10 in	147 cm 4 ft 10 in
Distance to the wall		I	57 cm 1 ft 10 in	57 cm 1 ft 10 in	57 cm 1 ft 10 in	57 cm 1 ft 10 in	57 cm 1 ft 10 in	57 cm 1 ft 10 in
Load height		J	30 cm 12 in	30 cm 12 in	30 cm 12 in	30 cm 12 in	30 cm 12 in	30 cm 12 in
FORKS								
Length		K	66 cm 2 ft 2 in	66 cm 2 ft 2 in	66 cm 2 ft 2 in	66 cm 2 ft 2 in	66 cm 2 ft 2 in	66 cm 2 ft 2 in
Maximum width		L _{MAX}	46.5 cm 1 ft 6.5 in	46.5 cm 1 ft 6.5 in	46.5 cm 1 ft 6.5 in	46.5 cm 1 ft 6.5 in	46.5 cm 1 ft 6.5 in	46.5 cm 1 ft 6.5 in
Minimum width		L _{min}	33 cm 1 ft 1 in	33 cm 1 ft 1 in	33 cm 1 ft 1 in	33 cm 1 ft 1 in	33 cm 1 ft 1 in	33 cm 1 ft 1 in



	TORO C-301/C	TORO C-302/C	TORO C-303	TORO C-304/C	TORO C-305	TORO C-306
↑	3,85 m 12 ft 7.5 in	5,00 m 16 ft 5 in	5,00 m 16 ft 5 in	6,00 m 19 ft 8 in	6,50 m 21 ft 4 in	8,00 m 26 ft 3 in
kg ↓	350 kg 772 lb	330 kg 728 lb	350 kg 772 lb	320 kg 705 lb	320 kg 705 lb	300 kg 661 lb
↓	1,60 m 5 ft 3 in	1,60 m 5 ft 3 in	1,98 m 6 ft 6 in	1,60 m 5 ft 3 in	1,98 m 6 ft 6 in	1,98 m 6 ft 6 in
kg	152 Kg 335 lb	169 Kg 373 lb	161 Kg 355 lb	182 Kg 401 lb	179 Kg 395 lb	197 Kg 434 lb

TORO MATERIAL LIFTS ARE EQUIPPED WITH TWO SAFETY SYSTEMS



Auto-brake winch.
CE Machinery Directives



Internal Pendulum
Brake System (IPB)



Mast Section Unblocking
System (MSU)

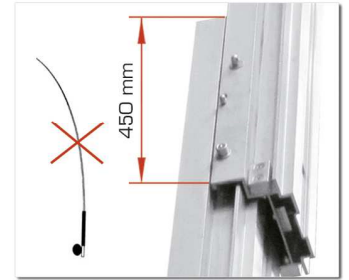

More mast overlap.
Prevents fishing rod effect



Adjustable manoeuvring
handle with Ø200 mm
wheels included.
(3 positions)



Reinforced forks included.
(Detachable). Reversible &
Adjustable design.



2 Stabiliser braces for
greater lift stability.



Adjustable mast blocking
system for horizontal transpor-
tation.



Folding side
legs included



Adjustable legs



Legs can be inserted in the front or
back of the tower for positioning
close to walls.



Spirit level



Ø150 mm adjustable
wheels for perfect
levelling.

Compact designs and 12 wheels included for
easy manoeuvring (Vertically and horizontally)

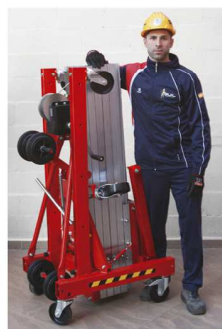

HRT HORQUILLAS FORK



ACT-01 DISEÑO CURVO PIPE CRADLE



ACT-04 PLATAFORMA LOAD PLATFORM



***ACT-02** PROLONGADORES FORK EXTENSIONS



***ACT-05** PLUMA CON GANCHO LOAD HOOK ARM



ACT-06 PERSIANAS Y PUERTAS ENROLLABLES ROLLER DOOR & WINDOW SHUTTERS



ACT-07 ADAPTADOR PARA ILUMINACIÓN FLOOD LIGHT ADAPTOR

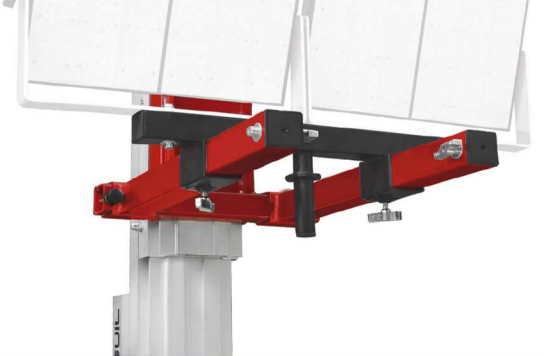

***ACT-08** PLUMA CON 5 POSICIONES 5-POSITION BOOM ARM

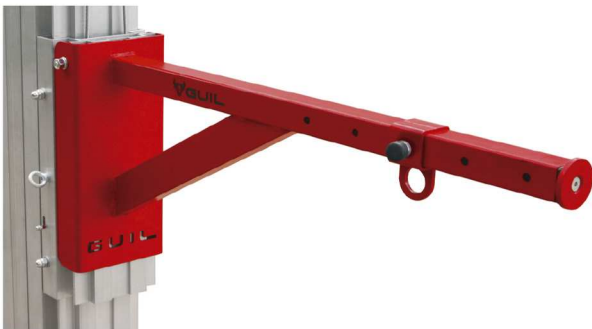

***ACT-09** EXPANSOR DE HORQUILLAS FORK WIDENER

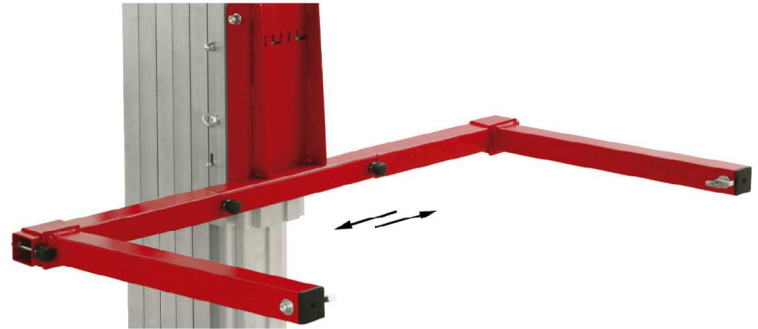

CONTRAPESOS Y BANDEJA COUNTERWEIGHTS & HOLDER



SISTEMA DE ELEVACIÓN ELÉCTRICO ELECTRIC LIFTING SYSTEM

***ELECTRIC**

2 Sistemas en 1 - Manual y Eléctrico
Práctico sistema que permite elevar la carga de manera eléctrica.
2 Systems in 1 - Manual & Electric
Practical system that allows you to raise the load electrically.

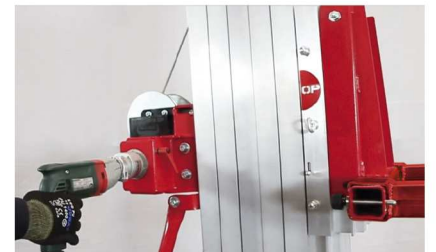

*Adaptador no válido para elevadores TORO Serie A

*This adaptor is not suitable for the A-Range towers.

Ref. ACT-08

Ref. ACT-10



VIDRIO
GLASS



CUBRECABLES PARA LOS ELEVADORES TORO CABLE COVER FOR **TORO** LIFTERS



Ref. **CBC**

SISTEMA DE ELEVACIÓN ELÉCTRICO

ELECTRIC LIFTING SYSTEM



ELECTRIC

Electric Lifting System for TORO Lifters (B - C - D Ranges)



With this practical and very safe system, you have the possibility to raise and lower the TORO material lifts electrically (ranges B, C and D); converting the manual towers into electric towers.

The 'ELECTRIC' system is a very useful accessory which allows you to quickly and effortlessly raise the TORO lifters guaranteeing utmost safety at all times.

The accessory is made up of an industrial drill (brand: METABO, Germany), a power reducer and an adaptor to secure it to the hand winch on the lifter.

The adaptor ensures a firm fix of the drill so that the user is not required to hold the drill in place, allowing to work with just one hand.



The 'ELECTRIC' system is installed quickly and easily and has the following references depending on the tower it will be used with:

TORO B-Range towers — ref. ELECTRIC-B/2

Adapter and drill for ELECTRIC operation of TORO B-Range Lifts. Price includes a single-handled AL-KO 901 winch to replace the double-handled BULL300-D (Net Weight: 7.30 kg – without winch)

TORO C-Range towers — ref. ELECTRIC-C/2

Adapter and drill for ELECTRIC operation of TORO C- & E-Range Lifts. Price includes a single-handled AL-KO 901 winch to replace the double-handled BULL400-D (Net Weight: 7.30 kg – without winch)

TORO D-Range towers — ref. ELECTRIC-D/2

Adapter and drill for ELECTRIC operation of TORO D-Range Lifts. (Net Weight: 7.10 kg)

NOTE: When this electric system is used the TORO D-Range towers have a maximum load capacity of 350 kg.

APPLICATIONS

GUIL manufactures a wide range of innovative material lifts, adapters and accessories designed to cover the needs for a large variety of applications:

| HVAC

| GLASS

| AWNINGS & SHELTERS

| ROLLER SHUTTERS & BLINDS

| INSTALLATIONS

| MAINTENANCE WORK

| PIPING & DUCTS

| METALWORK

| CARPENTRY

| EXHIBITION STANDS

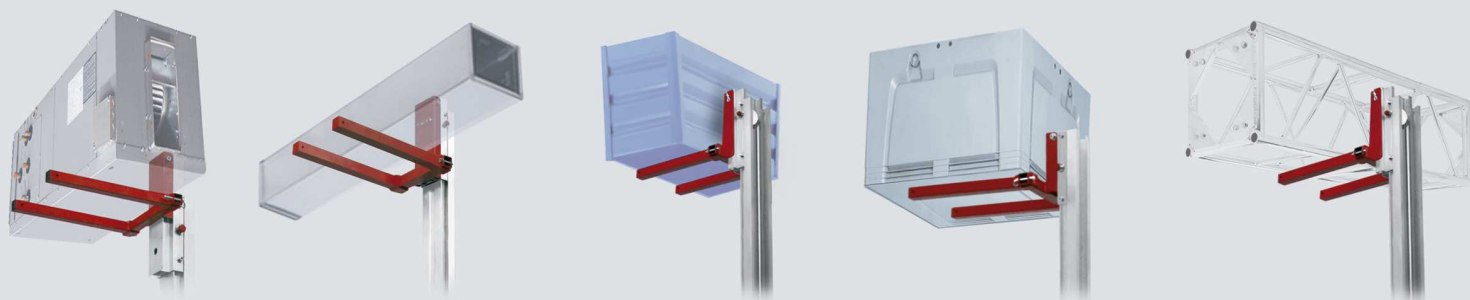

CHOOSE A MODEL & LIFT YOUR LOAD

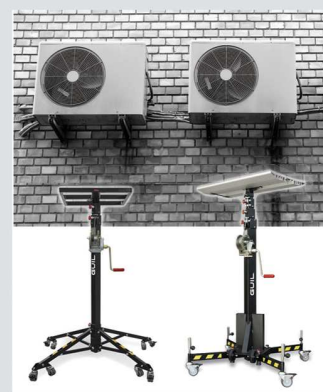

MADE IN SPAIN
www.guil-lifters.com



P.I. La Creu C/ Ismael Tomás Alacreu, 28-30 - CP 46250 L'Alcúdia (Valencia) SPAIN
Fax +34 962540833 Tel +34 962996500 info@guil.es

GUIL - YOUR EUROPEAN LIFTING TOWER MANUFACTURER

