

TORO D Range		TORO D-407	TORO D-406	TORO D-404	TORO D-401	TORO D-405/C	TORO D-403/C	TORO D-402/C	
Number of sections		5	4	3	2	5	4	3	
Maximum load		350 kg 772 lb	400 kg 882 lb	420 kg 926 lb	440 kg 970 lb	350 kg 772 lb	400 kg 882 lb	420 kg 926 lb	
Weight		215 kg 474 lb	195 kg 430 lb	172 kg 379 lb	154 kg 339 lb	196 kg 432 lb	179 kg 395 lb	163 kg 359 lb	
<b>STOWED</b>									
Height	A	198 cm 6 ft 6 in	198 cm 6 ft 6 in	198 cm 6 ft 6 in	198 cm 6 ft 6 in	160 cm 5 ft 3 in	160 cm 5 ft 3 in	160 cm 5 ft 3 in	
Length	B	95 cm 3 ft 1.5 in	95 cm 3 ft 1.5 in	95 cm 3 ft 1.5 in	95 cm 3 ft 1.5 in	95 cm 3 ft 1.5 in	95 cm 3 ft 1.5 in	95 cm 3 ft 1.5 in	
Width	C	66 cm 2 ft 2 in	66 cm 2 ft 2 in	66 cm 2 ft 2 in	66 cm 2 ft 2 in	66 cm 2 ft 2 in	66 cm 2 ft 2 in	66 cm 2 ft 2 in	
<b>WORKING MEASUREMENTS</b>									
Maximum height	Forks up	D <sub>1</sub>	800 cm 26 ft 3 in	650 cm 21 ft 4 in	500 cm 16 ft 5 in	355 cm 11 ft 8 in	600 cm 19 ft 8 in	500 cm 16 ft 5 in	385 cm 12 ft 7.5 in
	Forks down	D <sub>2</sub>	760 cm 24 ft 11 in	610 cm 20 ft	460 cm 15 ft 1 in	315 cm 10 ft 4 in	560 cm 18 ft 4.5 in	460 cm 15 ft 1 in	345 cm 11 ft 4 in
Length	Front legs	E <sub>1</sub>	192 cm 6 ft 3.5 in	192 cm 6 ft 3.5 in	192 cm 6 ft 3.5 in	192 cm 6 ft 3.5 in	192 cm 6 ft 3.5 in	192 cm 6 ft 3.5 in	192 cm 6 ft 3.5 in
	Back legs	E <sub>2</sub>	183 cm 6 ft	183 cm 6 ft	183 cm 6 ft	183 cm 6 ft	183 cm 6 ft	183 cm 6 ft	183 cm 6 ft
Width		F	66 cm 2 ft 2 in	66 cm 2 ft 2 in	66 cm 2 ft 2 in	66 cm 2 ft 2 in	66 cm 2 ft 2 in	66 cm 2 ft 2 in	
Leg height		G	28 cm 11 in	28 cm 11 in	28 cm 11 in	28 cm 11 in	28 cm 11 in	28 cm 11 in	
Width w/ stabilisers unfolded		H	147 cm 4 ft 10 in	147 cm 4 ft 10 in	147 cm 4 ft 10 in	147 cm 4 ft 10 in	147 cm 4 ft 10 in	147 cm 4 ft 10 in	
Distance to the wall		I	57 cm 1 ft 10 in	57 cm 1 ft 10 in	57 cm 1 ft 10 in	57 cm 1 ft 10 in	57 cm 1 ft 10 in	57 cm 1 ft 10 in	
Load height		J	30 cm 12 in	30 cm 12 in	30 cm 12 in	30 cm 12 in	30 cm 12 in	30 cm 12 in	
<b>FORKS</b>									
Length		K	66 cm 2 ft 2 in	66 cm 2 ft 2 in	66 cm 2 ft 2 in	66 cm 2 ft 2 in	66 cm 2 ft 2 in	66 cm 2 ft 2 in	
Maximum width		L <sub>MAX</sub>	46.5 cm 1 ft 6.5 in	46.5 cm 1 ft 6.5 in	46.5 cm 1 ft 6.5 in	46.5 cm 1 ft 6.5 in	46.5 cm 1 ft 6.5 in	46.5 cm 1 ft 6.5 in	
Minimum width		L <sub>min</sub>	35 cm 1 ft 2 in	35 cm 1 ft 2 in	35 cm 1 ft 2 in	35 cm 1 ft 2 in	35 cm 1 ft 2 in	35 cm 1 ft 2 in	



	TORO D-401	TORO D-402/C	TORO D-403/C	TORO D-404	TORO D-405/C	TORO D-406	TORO D-407
↑	3,55 m 11 ft 8 in	3,85 m 12 ft 7.5 in	5,00 m 16 ft 5 in	5,00 m 16 ft 5 in	6,00 m 19 ft 8 in	6,50 m 21 ft 4 in	8,00 m 26 ft 3 in
⬇️	440 kg 970 lb	420 kg 926 lb	400 kg 882 lb	420 kg 926 lb	350 kg 772 lb	400 kg 882 lb	350 kg 772 lb
↓	1,98 m 6 ft 6 in	1,60 m 5 ft 3 in	1,60 m 5 ft 3 in	1,98 m 6 ft 6 in	1,60 m 5 ft 3 in	1,98 m 6 ft 6 in	1,98 m 6 ft 6 in
⬇️	154 Kg 339 lb	163 Kg 359 lb	179 Kg 395 lb	172 Kg 379 lb	196 Kg 432 lb	195 Kg 430 lb	215 Kg 474 lb

# TORO Serie-D

## Details

TORO MATERIAL LIFTS ARE EQUIPPED WITH TWO SAFETY SYSTEMS



Auto-brake winch with double handle. CE Machinery Directives



Internal Pendulum Brake System (IPB)



Mast Section Unblocking System (MSU)

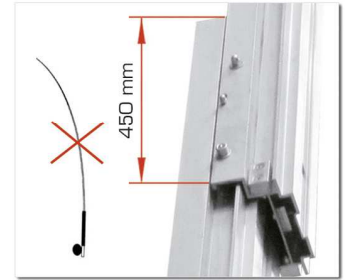

More mast overlap. Prevents fishing rod effect



Adjustable manoeuvring handle with Ø200 mm wheels included. (3 positions)



Reinforced forks included. (Detachable). Reversible & Adjustable design.



2 Stabiliser braces for greater lift stability.



Adjustable mast blocking system for horizontal transportation.



Folding side legs included



Legs can be inserted in the front or back of the tower for positioning close to walls.



Spirit level



Ø150mm adjustable wheels for perfect levelling.

Compact designs and 12 wheels included for easy manoeuvring (Vertically and horizontally)

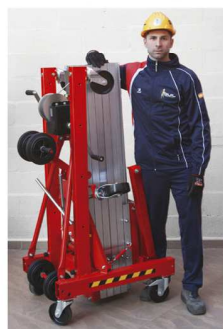

**HRT** HORQUILLAS FORK



**ACT-01** DISEÑO CURVO PIPE CRADLE



**ACT-04** PLATAFORMA LOAD PLATFORM



**\*ACT-02** PROLONGADORES FORK EXTENSIONS



**\*ACT-05** PLUMA CON GANCHO LOAD HOOK ARM



**ACT-06** PERSIANAS Y PUERTAS ENROLLABLES ROLLER DOOR & WINDOW SHUTTERS



**ACT-07** ADAPTADOR PARA ILUMINACIÓN FLOOD LIGHT ADAPTOR

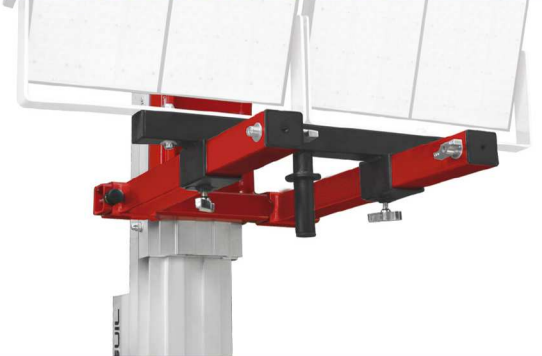

**\*ACT-08** PLUMA CON 5 POSICIONES 5-POSITION BOOM ARM

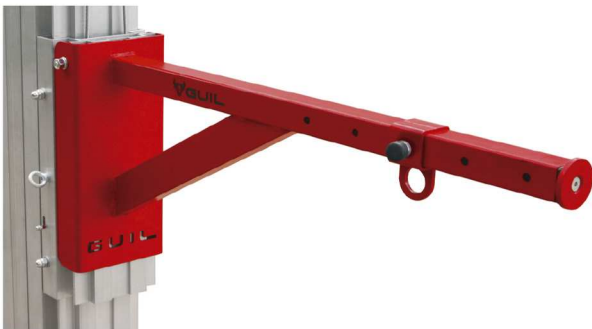

**\*ACT-09** EXPANSOR DE HORQUILLAS FORK WIDENER

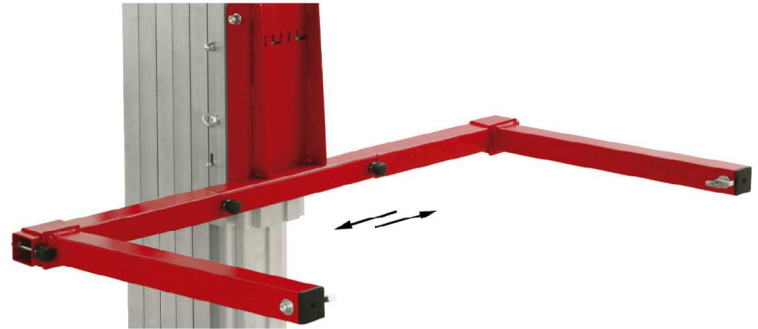

CONTRAPESOS Y BANDEJA COUNTERWEIGHTS & HOLDER



SISTEMA DE ELEVACIÓN ELÉCTRICO ELECTRIC LIFTING SYSTEM

**\*ELECTRIC**

**2 Sistemas en 1** - Manual y Eléctrico  
Práctico sistema que permite elevar la carga de manera eléctrica.  
**2 Systems in 1** - Manual & Electric  
Practical system that allows you to raise the load electrically.

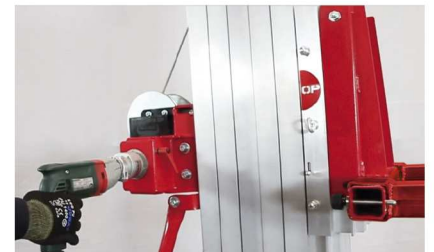

\*Adaptador no válido para elevadores TORO Serie A

\*This adaptor is not suitable for the A-Range towers.

# ADAPTADORES PARA VIDRIO ADAPTORS FOR GLASS

Ref. **ACT-08**

Ref. **ACT-10**



VIDRIO  
GLASS



# CUBRECABLES PARA LOS ELEVADORES TORO CABLE COVER FOR **TORO** LIFTERS



Ref. **CBC**

# SISTEMA DE ELEVACIÓN ELÉCTRICO

## ELECTRIC LIFTING SYSTEM



# ELECTRIC

### Electric Lifting System for TORO Lifters (B - C - D Ranges)



With this practical and very safe system, you have the possibility to raise and lower the TORO material lifts electrically (ranges B, C and D); converting the manual towers into electric towers.

The 'ELECTRIC' system is a very useful accessory which allows you to quickly and effortlessly raise the TORO lifters guaranteeing utmost safety at all times.

The accessory is made up of an industrial drill (brand: METABO, Germany), a power reducer and an adaptor to secure it to the hand winch on the lifter.

The adaptor ensures a firm fix of the drill so that the user is not required to hold the drill in place, allowing to work with just one hand.



The 'ELECTRIC' system is installed quickly and easily and has the following references depending on the tower it will be used with:

#### TORO B-Range towers — ref. ELECTRIC-B/2

Adapter and drill for ELECTRIC operation of TORO B-Range Lifts. Price includes a single-handled AL-KO 901 winch to replace the double-handled BULL300-D (Net Weight: 7.30 kg – without winch)

#### TORO C-Range towers — ref. ELECTRIC-C/2

Adapter and drill for ELECTRIC operation of TORO C- & E-Range Lifts. Price includes a single-handled AL-KO 901 winch to replace the double-handled BULL400-D (Net Weight: 7.30 kg – without winch)

#### TORO D-Range towers — ref. ELECTRIC-D/2

Adapter and drill for ELECTRIC operation of TORO D-Range Lifts. (Net Weight: 7.10 kg)

NOTE: When this electric system is used the TORO D-Range towers have a maximum load capacity of 350 kg.



# APPLICATIONS

GUIL manufactures a wide range of innovative material lifts, adapters and accessories designed to cover the needs for a large variety of applications:

| HVAC

| GLASS

| AWNINGS & SHELTERS

| ROLLER SHUTTERS & BLINDS

| INSTALLATIONS

| MAINTENANCE WORK

| PIPING & DUCTS

| METALWORK

| CARPENTRY

| EXHIBITION STANDS

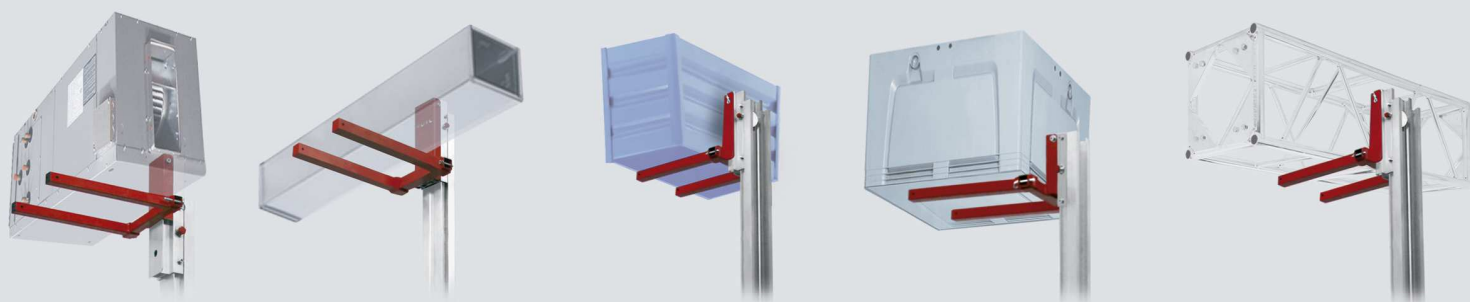

## CHOOSE A MODEL & LIFT YOUR LOAD

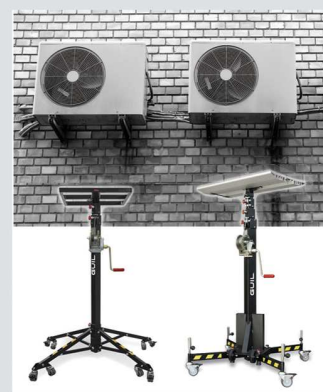

MADE IN SPAIN  
[www.guil-lifters.com](http://www.guil-lifters.com)



P.I. La Creu C/ Ismael Tomás Alacreu, 28-30 - CP 46250 L'Alcúdia (Valencia) SPAIN  
Fax +34 962540833 Tel +34 962996500 info@guil.es

GUIL - YOUR EUROPEAN LIFTING TOWER MANUFACTURER

