

Since 1983

2025



GUIL®

www.guil.es



ELEVADORES PARA
CLIMATIZACIÓN | REFRIGERACIÓN

LIFTERS FOR **HVAC**

GUIL, TU FABRICANTE DE ELEVADORES DE CARGA

GUIL, YOUR MATERIAL LIFTER MANUFACTURER

MADE IN SPAIN



ELIGE UN MODELO Y ELEVA TU CARGA

CHOOSE A MODEL AND LIFT YOUR LOAD

Nuestros elevadores son el complemento ideal para la instalación y montaje de:
Our lifters are the perfect solution for the installation and set-up of:

- | | |
|--------------------|------------------|
| CALEFACCIÓN | HEATING |
| VENTILACIÓN | VENTILATION |
| AIRE ACONDICIONADO | AIR CONDITIONING |
| REFRIGERACIÓN | REFRIGERATION |
| CONDUCTOS | DUCTS |
| TUBERÍAS | PIPES |
| PLACAS SOLARES | SOLAR PANELS |

DESCUBRE LA GAMA
Discover our Range

GUIL DISEÑA Y FABRICA ELEVADORES DE CARGA PARA HACER TU TRABAJO MÁS FÁCIL, RÁPIDO Y SEGURO

GUIL DESIGN AND MANUFACTURE LIFTERS TO MAKE YOUR JOB QUICKER, EASIER, AND SAFER



ELEVADORES PARA CALEFACCIÓN, VENTILACIÓN Y AIRE ACONDICIONADO

Somos una empresa española especializada en la **fabricación de ELEVADORES DE CARGA**, especialmente utilizados para la instalación y montaje de equipos de **Refrigeración, Ventilación, Calefacción y Climatización**.

Nuestros elevadores permiten aumentar la seguridad de los operarios durante los montajes y reducen los tiempos de instalación, con el consecuente incremento en la productividad.

Desde nuestros inicios, en **1983**, hemos ido ampliando nuestra gama para satisfacer las necesidades de su sector, **desarrollando modelos muy compactos que permiten realizar montajes en espacios reducidos**.

AHORRO DE TIEMPO > AUMENTO DE PRODUCTIVIDAD
TIME SAVED > INCREASED PRODUCTIVITY

MATERIAL LIFTERS FOR HEATING, VENTILATION & AIR-CONDITIONING EQUIPMENT



GUIL is a Spanish company that specialises in the **manufacture of MATERIAL LIFTERS** and their accessories, particularly those used in installation and set-up of **Refrigeration, Ventilation, Heating and Air-Conditioning equipment**.

Our lifters allow installation time to be reduced, and worker safety to be increased during set-up, with the consequent gain in productivity.

Since the company was founded, in **1983**, we have been continuously increasing our range to satisfy the needs of the sector, **developing very compact models that allow installations to be carried out even in reduced spaces**.





La Solución definitiva para
INSTALAR EQUIPOS DE HVAC

The definitive solution to
INSTALL HVAC EQUIPMENT





ELEVADORES CON MEDIDAS REDUCIDAS PARA LA INSTALACIÓN EN BALCONES Y ESPACIOS LIMITADOS

LIFTERS WITH A SMALL FOOTPRINT FOR INSTALLATIONS ON BALCONIES OR SIMILAR REDUCED SPACES

GUIL fabrica una amplia gama de elevadores y adaptadores para facilitar el trabajo de los profesionales del Sector de la Climatización y Refrigeración. Nuestros elevadores son la herramienta de trabajo perfecta para cualquier instalador, facilitando el montaje de equipos y conductos a diferentes alturas, tanto en interiores como en exteriores, e incluso en el interior de techos registrables.

GUIL manufacture lifters and adaptors to help make HVAC installers' lives easier. Not many jobs are carried out 3 or 4 metres off the ground – or more! –, but that is the case of HVAC installation. The units are fastened high on the wall, both inside and out, or even on or inside the ceiling. Ventilation ducts can be fixed a lot higher than that, too! The perfect present for an installer will be something to help to get those units up to their working height and keep them there while they're fastened in place – and all without effort.





► PRODUCTIVIDAD Y EFICIENCIA

Los elevadores GUIL le ayudarán a finalizar sus trabajos de manera **más rápida y eficiente**, subiendo las unidades de aire acondicionado o conductos de ventilación y manteniéndolos en posición durante su instalación. Ya no tendrá que subir por una escalera con la unidad de aire acondicionado o el conducto en sus manos: **Deje que su elevador GUIL haga el trabajo duro.**® Hacer el trabajo más rápido permite **aumentar su productividad**, pudiendo realizar más montajes, o simplemente tener más tiempo libre para disfrutar.

► PRODUCTIVITY & EFFICIENCY

GUIL's lifters will help you to complete jobs **more quickly and efficiently**, lifting your air-conditioning unit, or ventilation ducting, and holding it in position while you fix it in place. No more struggling up a step-ladder with the A/C block or duct in your hands: **Just let your GUIL lifter do the hard work.**®

Getting the job done more quickly, of course, **increases your productivity**, and means you can do more jobs in a week – or have more free time at the end of the day. The time that you save at work is yours to use later – for work or leisure.

INSTALACIÓN DE UNIDAD EXTERIOR DE AIRE ACONDICIONADO

1. ELEVA la unidad exterior



2. POSICIONA el elevador



3. DESCENDE el elevador



INSTALLATION OF AIR-CONDITIONER OUTDOOR UNIT

1. LIFT the outdoor unit

2. POSITION the lifter with the unit

3. LOWER the platform

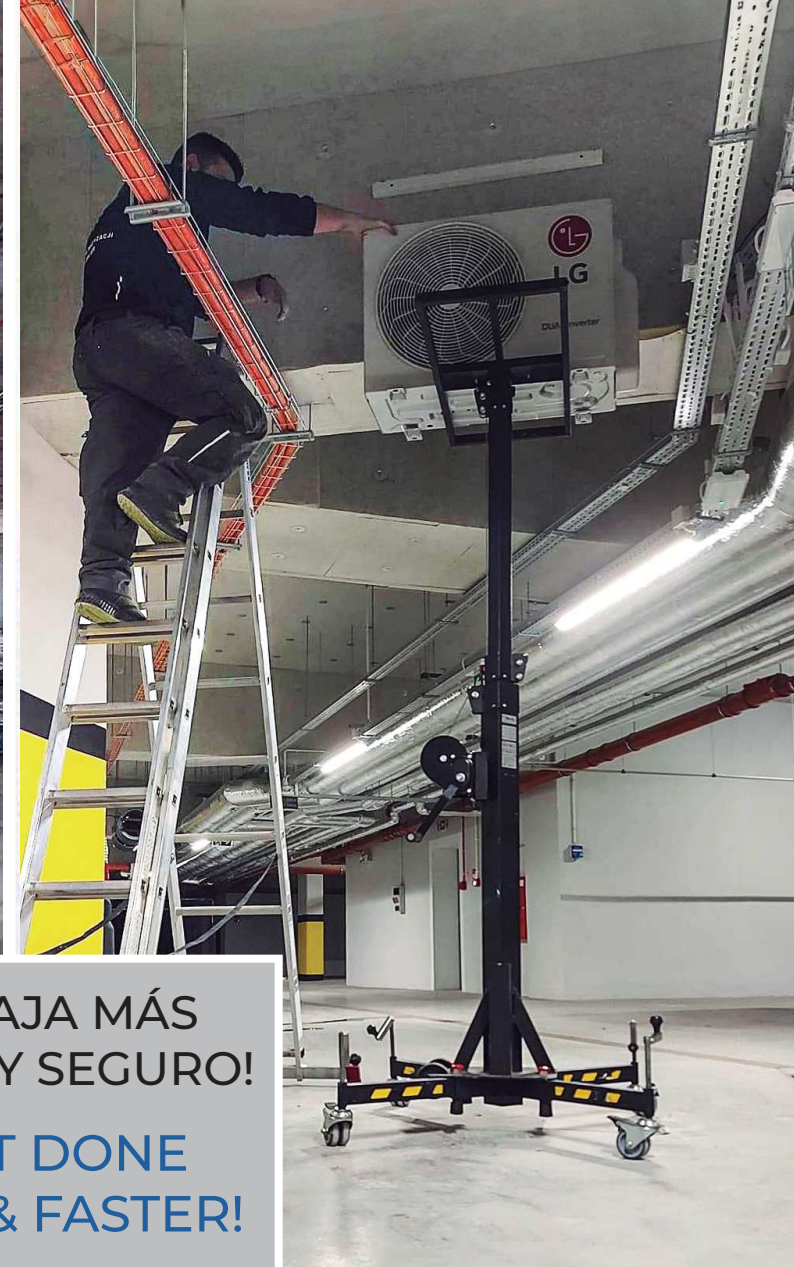
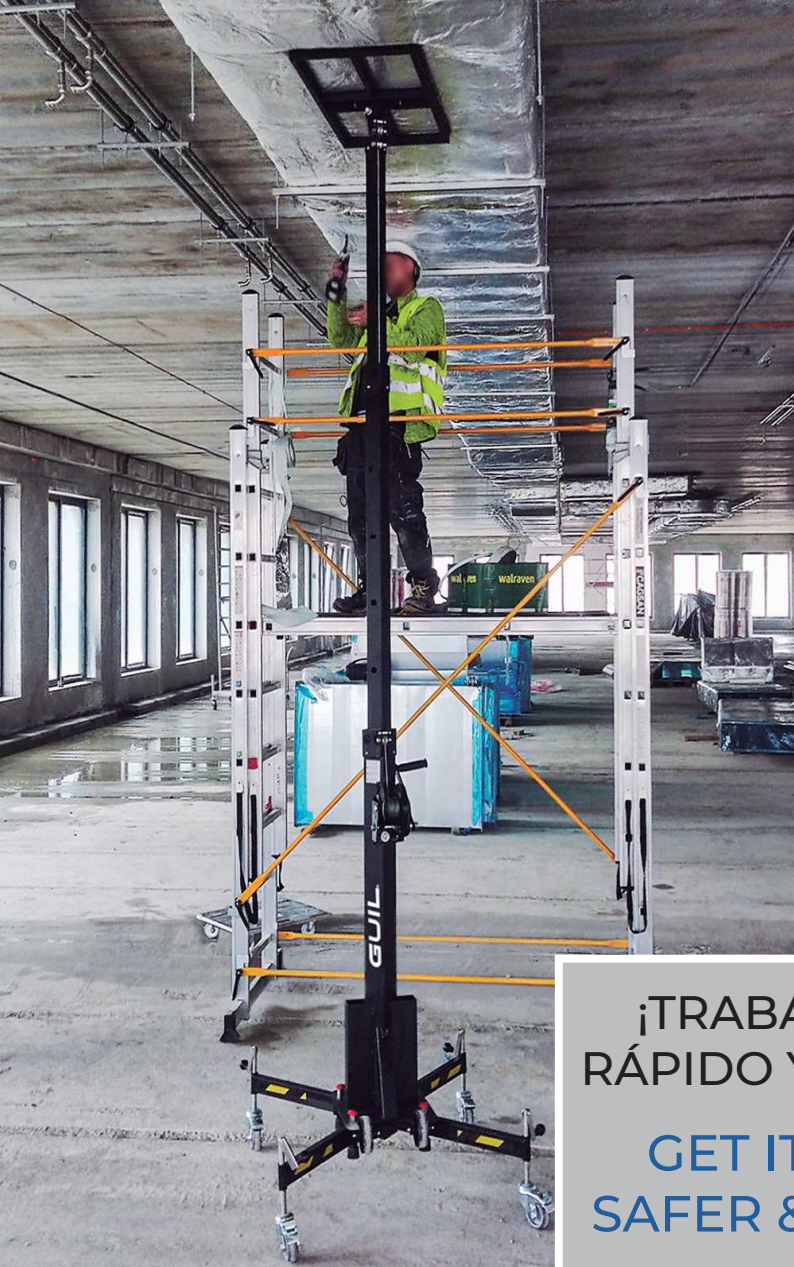

¡TRABAJA MÁS RÁPIDO Y SEGURO!
GET IT DONE SAFER & FASTER!

► SEGURIDAD EN EL TRABAJO

Los elevadores GUIL aportan la seguridad que los técnicos necesitan durante las instalaciones, eliminando los riesgos derivados de la manipulación en altura de elementos pesados o voluminosos.

Todos nuestros elevadores están equipados con dispositivos de nivelación que garantizan una perfecta estabilidad.

En GUIL fabricamos elevadores con materiales y componentes de alta calidad para garantizar la máxima seguridad, resistencia y durabilidad.

► SAFETY AT WORK

GUIL lifters **improve security for installers**, eliminating risks from handling heavy or bulky items at height.

All our lifters are fitted with levelling mechanisms which ensure perfect stability.

The high-quality materials and components used in our lifters guarantee the strength and reliability that protect workers at all times, ensuring many years of safe, trouble-free air-conditioning or ventilation installation.

At GUIL, we manufacture lifters using high-quality materials and components to guarantee maximum safety, strength and durability.



► DISEÑOS LIGEROS Y COMPACTOS

Fabricamos elevadores ligeros y compactos para poder ser utilizados en instalaciones de equipos HVAC en pequeños espacios o de difícil acceso (balcones, baños, pequeños almacenes, etc). Las reducidas dimensiones de los elevadores de la serie ELC, permiten su carga y transporte en pequeños vehículos, incluso en maleteros.

Los elevadores TORO están provistos de ruedas para su transporte tanto en vertical como en horizontal. Fabricamos modelos compactos con alturas plegadas de tan sólo 1,60 m. Los modelos TORO de la serie B, C y D están equipados con patas estabilizadoras laterales que se pueden desplegar milímetro a milímetro contra las paredes o directamente al suelo y de patas extensibles en su base, que permiten varias posiciones para que los elevadores se puedan montar en pequeñas estancias. Nuestro diseño exclusivo de elevador "2 en 1", permite su utilización tanto como elevadores estándar, como dispositivos con contrapeso, permitiendo trabajar a rás de pared.

► LIGHT, COMPACT DESIGNS

GUIL makes light, compact lifters, whose **small footprint** allows them to be set up to install HVAC equipment in places such as balconies, stairwells, bathrooms or small storerooms, where there is poor access and not much space. With their small stowed dimensions and detachable legs, they can also be easily loaded and transported in small vans, or even in car boots.

Our front-loading lifters are compact, with stowed heights of as little as 1.60 m, and are equipped with wheels, for horizontal or vertical transportation and easy loading into vehicles. Our TORO B-, C- and D-range machines have side stabiliser legs that can be deployed against walls or the ground, and extendible base legs with several positions for greater flexibility. GUIL's exclusive "2-in-1" design allows a single lifter to be used both as a standard model or a counterbalance one, allowing it to be placed next to walls or other worksurfaces.



► GRAN VARIEDAD DE OPCIONES

GUIL ofrece a los profesionales del sector HVAC más de 30 modelos de elevadores, diseñados para cargas desde los 85 kg hasta los 440 kg, y alturas de elevación desde los 3,30 m hasta los 8 m. Fabricamos una amplia variedad de accesorios: plataformas de diferentes tamaños, cunas para conductos cilíndricos, ruedas para un mejor posicionamiento del elevador, etc.

En GUIL podrá encontrar la combinación ideal de elevador y accesorio para subir e instalar sus equipos de HVAC.

► WIDE RANGE

With GUIL, you have at your disposal over 30 models of lifters for HVAC equipment, with maximum loads from 85 kg to 440 kg, and lifting heights from 3.30 m to 8 m. Use our wide variety of attachments: platforms of different sizes, cradles for cylindrical objects, wheels for easy positioning, etc. **Check out our range to find the ideal lifter-plus-attachment combination for all your HVAC needs.**

GUIL, TU FABRICANTE DE ELEVADORES GUIL, YOUR MATERIAL LIFTER MANUFACTURER



GUIL OFRECE

Nuestra Experiencia Desde 1983



40 años en el campo de la elevación de carga nos avalan. Nuestra máxima es la de superarnos día a día, garantizando la fabricación del mejor producto con la más alta calidad.

Productos Certificados



Todos nuestros Elevadores cumplen con los más altos estándares de seguridad, superando las expectativas de nuestros clientes y cumpliendo con las directivas europeas más exigentes.

Our experience. Since 1983



Backed up by 40 years in the field of lifting and maintenance. We have always strived to surpass ourselves every day, ensuring that we manufacture the best products with the highest quality.

Certified Products



All our Lifters comply with the market's most demanding regulations and standards, exceeding our customers' expectations and observing the most demanding European directives.

A la vanguardia en Diseño y Tecnología



Contamos con los equipos más innovadores para el desarrollo y la fabricación de nuestros Elevadores, siempre pensando en las necesidades del mercado.

Cooperación y Flexibilidad



Nuestro equipo técnico está siempre dispuesto a ayudarles en la elección de los Elevadores y accesorios que mejor se ajusten a sus necesidades.

Pioneers in Design and Technology



We have the most advanced machines available for the development and manufacture of our Material Lifts, and are constantly focused on the needs of the market.

Cooperation and Flexibility



Our specialised team will always be ready to help you choose the Lifters and accessories that best suit your needs.

Calidad 100% Garantizada



En la fabricación de nuestros Elevadores utilizamos materias primas y componentes de la más alta calidad. En GUIL consideramos que la Seguridad es lo más importante.

Servicio y Compromiso



Nuestros clientes están en el centro de todo lo que hacemos. Nos volcamos por completo en su atención, transmitiéndoles la pasión por lo que hacemos y el orgullo de nuestra marca.

Quality 100% Guaranteed



We use the highest-quality raw materials and components to manufacture our Lifting Towers and their accessories. At GUIL we believe that Safety is the maximum priority.

Service and Commitment



Our customers are at the center of all what we do. We are fully at your service, transmitting to you the passion for what we do and how proud we are of our brand.

¿A qué altura necesitas llegar? ¿Cuánto peso necesitas elevar?
Elige el modelo de elevador GUIL que más se adapta a tus necesidades

How high do you need to go? How much do you need to lift?
Which GUIL lifter can help you best?

ELEVADORES DE CARGA

ELC

MATERIAL LIFTERS



ELC	Altura Máx. Max. Height	Carga Máx. Max. Load	Altura Plegada Stowed Height	Peso Neto Net Weight
ELC-700	3.30 m (10 ft 10 in)	85 kg (187 lb)	1.70 m (5 ft 7 in)	13 kg (29 lb)
ELC-710	4.00 m (13 ft 1 in)	100 kg (220 lb)	1.65 m (5 ft 5 in)	20.5 kg (45 lb)
ELC-720/I	3.50 m (11 ft 6 in)	125 kg (276 lb)	1.35 m (4 ft 5 in)	25 kg (55 lb)
ELC-730/R	4.60 m (15 ft 1 in)	125 kg (276 lb)	1.51 m (15 ft)	42 kg (93 lb)



ELC	Altura Máx. Max. Height	Carga Máx. Max. Load	Altura Plegada Stowed Height	Peso Neto Net Weight
ELC-725	4.00 m (13 ft 1 in)	125 kg (276 lb)	1.32 m (4 ft 4 in)	50 kg (110 lb)
ELC-725/D	4.00 m (13 ft 1 in)	125 kg (276 lb)	1.32 m (4 ft 4 in)	51 kg (112 lb)
ELC-750	4.50 m (14 ft 9 in)	150 kg (331 lb)	1.53 m (5 ft)	49 kg (108 lb)
ELC-765	5.22 m (17 ft 2 in)	230 kg (507 lb)	1.77 m (5 ft 10 in)	98 kg (216 lb)
ELC-775	5.22 m (17 ft 2 in)	270 kg (595 lb)	1.77 m (5 ft 10 in)	100 kg (220 lb)
ELC-785	5.22 m (17 ft 2 in)	300 kg (661 lb)	1.77 m (5 ft 10 in)	102.5 kg (226 lb)



BC-02
800 x 400 mm



BC-06
450 x 450 mm



Aluminio
Aluminium

BC-09
800 x 400 mm



TOLDOS

AWNING

BC-11

BANDEJAS DE CARGA PLEGABLES

LOAD TRAYS (FOLDING DESIGN)

BC-05



740 x 435 x 140 mm

Medidas Plegada:
Folded Dimensions:
450 x 435 x 150 mm



Aluminio Aluminium

BC-07



450 x 435 x 140 mm

Medidas Plegada:
Folded Dimensions:
450 x 230 x 150 mm



Aluminio Aluminium

RUEDAS PARA ELEVADORES

WHEELS FOR MATERIAL LIFTERS



RD-02

Para / For Ref. ELC-730/R
(Ø 170 mm)



R-720

Juego de 4 ruedas
Set of 4 leg adaptors
Para / For Ref. ELC-720/1



R2-710

Juego de 3 ruedas
Set of 3 leg adaptors
Para / For Ref. ELC-710



PIQUETAS

GROUND FIXINGS

CPS-01

Juego de 3 Calzos
Set of 3 leg adaptors
Para ELC-710/ For ELC-710



CPS-02

Juego de 4 Calzos
Set of 4 leg adaptors
Para ELC-720/ For ELC-720



CARGAS CURVAS

PIPE CRADLE

CV-10



ILUMINACIÓN

FLOOD-LIGHT ADAPTORS

FCA-04



FCA-06



ACT-07



PARA CARPAS

FOR MARQUEES

ADT-100





TORO Serie A TORO A-Range	Altura Máxima Maximum Height	Carga Maxima Maximum Load	Altura Plegada Stowed Height	Peso Neto Net Weight
TORO A-101/C	2,90 m (9 ft 6 in)	170 kg (375 lb)	1,75 m (5 ft 9 in)	73 kg (161 lb)
TORO A-102/C	4,10 m (13 ft 5 in)	170 kg (375 lb)	1,75 m (5 ft 9 in)	85 kg (187 lb)



TORO Serie B TORO B-Range	Altura Máxima Maximum Height	Carga Maxima Maximum Load	Altura Plegada Stowed Height	Peso Neto Net Weight
TORO B-201 PLUS	5.00 m (16 ft 5 in)	250 kg (551 lb)	1.96 m (6 ft 5 in)	125 kg (276 lb)
TORO B-201/C	4.00 m (3 ft 1.5 in)	250 kg (551 lb)	1.66 m (5 ft 5 in)	125 kg (276 lb)
TORO B-202 PLUS	6.50 m (21 ft 4 in)	230 kg (507 lb)	1.96 m (6 ft 5 in)	141 kg (311 lb)
TORO B-202/C	5.15 m (16 ft 11 in)	230 kg (507 lb)	1.66 m (5 ft 5 in)	132 kg (291 lb)
TORO B-203/C	6.30 m (20 ft 8 in)	220 kg (485 lb)	1.66 m (5 ft 5 in)	139 kg (306 lb)



TORO Serie C TORO C-Range	Altura Máxima Maximum Height	Carga Maxima Maximum Load	Altura Plegada Stowed Height	Peso Neto Net Weight
TORO C-301/C	3.85 m (12 ft 8 in)	350 kg (772 lb)	1.60 m (5 ft 3 in)	152 kg (335 lb)
TORO C-302/C	5.00 m (16 ft 5 in)	330 kg (727 lb)	1.60 m (5 ft 3 in)	169 kg (373 lb)
TORO C-303	5.00 m (16 ft 5 in)	350 kg (772 lb)	1.98 m (6 ft 6 in)	161 kg (355 lb)
TORO C-304/C	6.00 m (19 ft 8 in)	320 kg (705 lb)	1.60 m (5 ft 3 in)	182 kg (401 lb)
TORO C-305	6.50 m (21 ft 4 in)	320 kg (705 lb)	1.98 m (6 ft 6 in)	178 kg (392 lb)
TORO C-306	8.00 m (26 ft 3 in)	300 kg (661 lb)	1.98 m (6 ft 6 in)	195 kg (430 lb)



TORO Serie D TORO D-Range	Altura Máxima Maximum Height	Carga Maxima Maximum Load	Altura Plegada Stowed Height	Peso Neto Net Weight
TORO D-401	3.55 m (11 ft 8 in)	440 kg (970 lb)	1.98 m (6 ft 6 in)	154 kg (339 lb)
TORO D-402/C	3.85 m (12 ft 8 in)	420 kg (926 lb)	1.60 m (5 ft 3 in)	163 kg (359 lb)
TORO D-403/C	5.00 m (16 ft 5 in)	400 kg (970 lb)	1.60 m (5 ft 3 in)	179 kg (395 lb)
TORO D-404	5.00 m (16 ft 5 in)	420 kg (926 lb)	1.98 m (6 ft 6 in)	172 kg (379 lb)
TORO D-405/C	6.00 m (19 ft 8 in)	350 kg (772 lb)	1.60 m (5 ft 3 in)	196 kg (432 lb)
TORO D-406	6.50 m (21 ft 4 in)	400 kg (970 lb)	1.98 m (6 ft 6 in)	195 kg (430 lb)
TORO D-407	8.00 m (26 ft 3 in)	350 kg (772 lb)	1.98 m (6 ft 6 in)	215 kg (474 lb)



TORO Serie E TORO E-Range	Altura Máxima Maximum Height	Carga Maxima Maximum Load	Altura Plegada Stowed Height	Peso Neto Net Weight
TORO E-501/C	3.45 m (11 ft 4 in)	200 kg (441 lb)	1.61 m (5 ft 3 in)	120 kg (265 lb)

HRT HORQUILLAS FORK



INCLUIDAS
INCLUDED

ACT-01 DISEÑO CURVO PIPE CRADLE

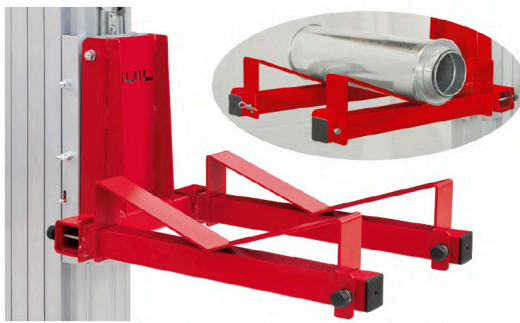

ACT-04 PLATAFORMA LOAD PLATFORM



ACT-04/M
Madera
Plywood

Aluminio
Aluminium

*ACT-02 PROLONGADORES FORK EXTENSIONS



*ACT-05 PLUMA CON GANCHO LOAD HOOK ARM



ACT-06 PERSIANAS Y PUERTAS ENROLLABLES
ROLLER DOOR & WINDOW SHUTTERS



ACT-07 ADAPTADOR PARA ILUMINACIÓN
FLOOD LIGHT ADAPTOR



*ACT-08 PLUMA CON 5 POSICIONES
5-POSITION BOOM ARM

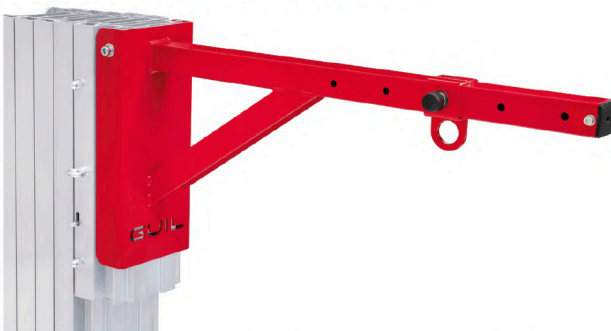

*ACT-09 EXPANSOR DE HORQUILLAS FORK WIDENER



CONTRAPESOS Y BANDEJA
COUNTERWEIGHTS & HOLDER



*CB-01



*CW-01/20
20 KG



SISTEMA DE ELEVACIÓN ELÉCTRICO
ELECTRIC LIFTING SYSTEM

***ELECTRIC**

2 Sistemas en 1 - Manual y Eléctrico
Práctico sistema que permite elevar la carga de manera eléctrica.
2 Systems in 1 - Manual & Electric
Practical system that allows you to raise the load electrically.



*Adaptador no válido para elevadores TORO Serie A

*This adaptor is not suitable for the A-Range towers.

Gracias a la amplia gama de modelos, adaptadores y accesorios, nuestros elevadores se utilizan en multitud de sectores, gozando de un gran reconocimiento mundial por su alta calidad y resistencia

Thanks to the wide range of models, adaptors and accessories, our lifting towers are used in many fields, and are acknowledged worldwide for their high quality and durability

Múltiples APLICACIONES:

► CLIMATIZACIÓN

- | TOLDOS Y PÉRGOLAS
- | VIDRIO
- | CONSTRUCCIÓN
- | INSTALACIONES Y MANTENIMIENTO
- | ALMACENAMIENTO Y LÓGISTICA
- | CERRAJERÍA Y CARPINTERIA
- | RECINTOS FERIALES
- | PERSIANAS ENROLLABLES
- | RÓTULOS Y SEÑALIZACIÓN

Multiple APPLICATIONS:

► HVAC

- | AWNINGS & PERGOLAS
- | GLASS
- | CONSTRUCTION
- | INSTALLATIONS & MAINTENANCE WORK
- | STORAGE & WAREHOUSING
- | METALWORK & CARPENTRY
- | EXHIBITION STANDS
- | ROLLER SHUTTERS & BLINDS
- | SIGNS & ADVERTS

ELEVADORES GUIL

La Solución para los
INSTALADORES

GUIL's LIFTERS

The ultimate Solution for **INSTALLERS**



Elevadores para
CLIMATIZACIÓN
Lifters for **HVAC**

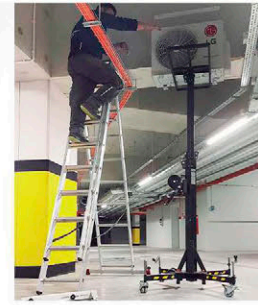

Elevadores para
PROTECCIÓN SOLAR
Lifters for
SOLAR PROTECTION

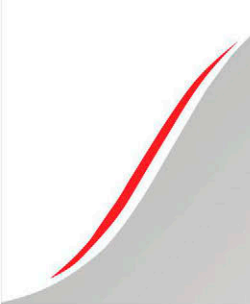

Elevadores para
VIDRIO
Lifters for **GLASS**

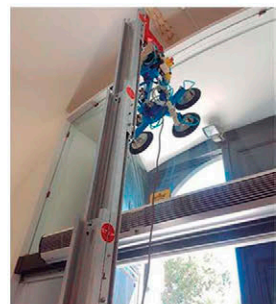

Elevadores para
CONSTRUCCIÓN
Lifters for
CONSTRUCTION



Elevadores para
ALMACENAJE
Lifters for **STORAGE**

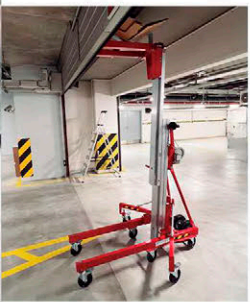
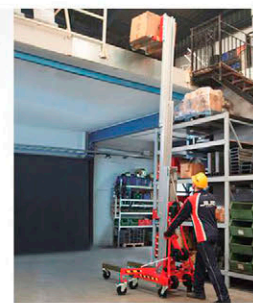

Elevadores para
OTROS USOS
Lifters for **OTHER USES**





**THE BEST LIFTERS
FOR THE BEST PROFESSIONALS**



P.I. La Creu C/ Ismael Tomás Alacreu, 28-30
46250 - L'Alcúdia (Valencia) **SPAIN**
Tel. +34 962996500 - info@guil.es
www.guil-lifters.com
www.elevadoresdecarga.es



**QUALITY
GUARANTEED**