

# TORO D-Range Material Lifts



	TORO D-401	TORO D-402/C	TORO D-403/C	TORO D-404	TORO D-405/C	TORO D-406	TORO D-407
↑	3.55 m 11 ft 8 in	3.85 m 12 ft 8 in	5.00 m 16 ft 5 in	5.00 m 16 ft 5 in	6.00 m 19 ft 8 in	6.50 m 21 ft 4 in	8.00 m 26 ft 3 in
kg ↓	400 kg 882 lb	400 kg 882 lb	400 kg 882 lb	400 kg 882 lb	350 kg 772 lb	400 kg 882 lb	350 kg 772 lb
↓	1.99 m 6 ft 6 in	1.61 m 5 ft 3 in	1.61 m 5 ft 3 in	1.99 m 6 ft 6 in	1.61 m 5 ft 3 in	1.99 m 6 ft 6 in	1.99 m 6 ft 6 in
kg	165 Kg 364 lb	175 Kg 386 lb	191 Kg 421 lb	184 Kg 406 lb	207 Kg 456 lb	203 Kg 448 lb	220 Kg 485 lb

# TORO D-Range Details

TORO MATERIAL LIFTS ARE EQUIPPED WITH TWO SAFETY SYSTEMS



Auto-brake winch with double handle. CE Machinery Directives



Internal Pendulum Brake System (IPB)



Mast Section Unblocking System (MSU)

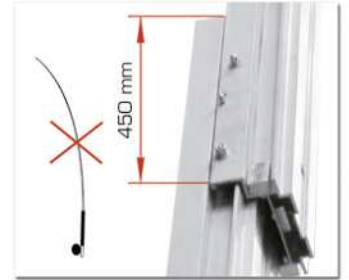

More mast overlap. Prevents fishing rod effect



Adjustable manoeuvring handle with Ø200 mm wheels included. (3 positions)



Reinforced forks included. (Detachable). Reversible & Adjustable design.



2 Stabiliser braces for greater lift stability.



Adjustable mast blocking system for horizontal transportation.



Spirit level



Legs can be inserted in the front or back of the tower for positioning close to walls.

Folding side legs included



Adjustable legs

Compact designs and 12 wheels included for easy manoeuvring (Vertically and horizontally)



Ø150mm adjustable wheels for perfect levelling.





# TORO Serie-D Specifications

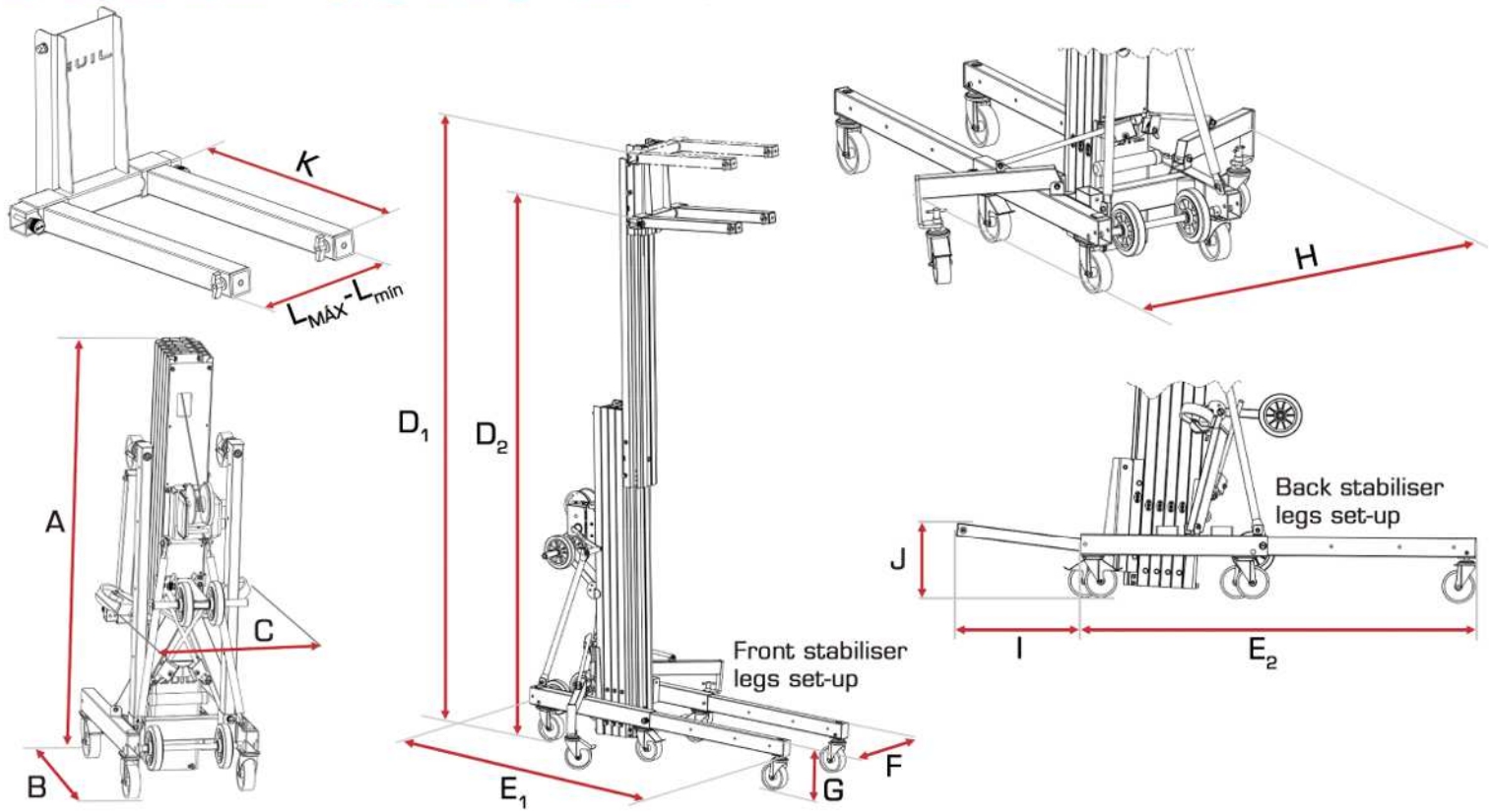

TORO D - Range		TORO D-401	TORO D-402/C	TORO D-403/C	TORO D-404	TORO D-405/C	TORO D-406	TORO D-407	
<b>STOWED</b>									
Height (cm/ft)	A	199 / 6.5	161 / 5.3	161 / 5.3	199 / 6.5	161 / 5.3	199 / 6.5	199 / 6.5	
Length (cm/ft)	B	95 / 3.1	95 / 3.1	95 / 3.1	95 / 3.1	95 / 3.1	95 / 3.1	95 / 3.1	
Width (cm/ft)	C	65 / 2.1	65 / 2.1	65 / 2.1	65 / 2.1	65 / 2.1	65 / 2.1	65 / 2.1	
<b>WORKING MEASUREMENTS</b>									
Maximum height (cm/ft)	Forks up	D <sub>1</sub>	355 / 11.7	385 / 12.6	500 / 16.4	500 / 16.4	600 / 19.7	650 / 21.3	800 / 26.2
	Forks down	D <sub>2</sub>	315 / 10.3	345 / 11.3	460 / 15.1	460 / 15.1	560 / 18.4	610 / 20	760 / 24.9
Length (cm/ft)	Front legs	E <sub>1</sub>	192 / 6.3	192 / 6.3	192 / 6.3	192 / 6.3	192 / 6.3	192 / 6.3	192 / 6.3
	Back legs	E <sub>2</sub>	183 / 6	183 / 6	183 / 6	183 / 6	183 / 6	183 / 6	183 / 6
Width (cm/ft)	F	64.5 / 2.1	64.5 / 2.1	64.5 / 2.1	64.5 / 2.1	64.5 / 2.1	64.5 / 2.1	64.5 / 2.1	
Leg height (cm/ft)	G	30 / 1	30 / 1	30 / 1	30 / 1	30 / 1	30 / 1	30 / 1	
Width with stabilisers unfolded (cm/ft)	H	147 / 4.8	147 / 4.8	147 / 4.8	147 / 4.8	147 / 4.8	147 / 4.8	147 / 4.8	
Distance to the wall (cm/ft)	I	57 / 1.9	57 / 1.9	57 / 1.9	57 / 1.9	57 / 1.9	57 / 1.9	57 / 1.9	
Load height (cm/ft)	J	33 / 1.1	33 / 1.1	33 / 1.1	33 / 1.1	33 / 1.1	33 / 1.1	33 / 1.1	
<b>FORKS</b>									
Length (cm/in)	K	66 / 26	66 / 26	66 / 26	66 / 26	66 / 26	66 / 26	66 / 26	
Maximum width (cm/in)	L <sub>MAX</sub>	47.5 / 18.7	47.5 / 18.7	47.5 / 18.7	47.5 / 18.7	47.5 / 18.7	47.5 / 18.7	47.5 / 18.7	
Minimum width (cm/in)	L <sub>MIN</sub>	35.5 / 14	35.5 / 14	35.5 / 14	35.5 / 14	35.5 / 14	35.5 / 14	35.5 / 14	
Number of sections		2	3	4	3	5	4	5	
Maximum load (Kg/lbs)		400 / 882	400 / 882	400 / 882	400 / 882	350 / 772	400 / 882	350 / 772	
Weight (Kg/lbs)		165 / 364	175 / 386	191 / 421	184 / 406	207 / 456	203 / 448	220 / 485	

# ADAPTORS & ACCESSORIES TORO

**HRT** FORK



**ACT-01** PIPE CRADLE



**ACT-04** LOAD PLATFORM



**ACT-06** ADAPTOR FOR ROLLER DOOR & WINDOW SHUTTERS



**ACT-03** BOOM ARM



**ACT-05** HOOK



**ACT-02** FORK LENGTHENERS



**ACT-07** FLOOD LIGHT ADAPTOR



**CW-01/20**

20 KG  
COUNTERWEIGHT



**CB-01**

COUNTERWEIGHT HOLDER





## Electric Lifting System for TORO Lifters (B - C - D Ranges)

Practical and very safe system that gives the option to raise and lower the TORO material lifts electrically (ranges B, C and D); converting the manual towers into electric towers.

The 'ELECTRIC' system is a very useful accessory which allows you to quickly and effortlessly raise the TORO lifters guaranteeing utmost safety at all times.



The accessory is made up of a 750W METABO drill and an adaptor to secure it to the hand winch on the lifter. The adaptor ensures a firm fix of the drill so that the user is not required to hold the drill in place. This detail not only makes it effortless to use but also prevents possible risk of bodily injuries.

The 'ELECTRIC' system is installed quickly and easily and have the following references depending on the tower it will be used with:

- TORO B-Range lifters – ref. ELECTRIC B
- TORO C-Range lifters – ref. ELECTRIC C
- TORO D-Range lifters – ref. ELECTRIC D



NOTE: When this electric system is used the TORO D-Range towers have a maximum load capacity of 350 kg.



# APPLICATIONS

GUIL manufactures a wide range of innovative material lifts, adapters and accessories designed to cover the needs for a large variety of applications:

## INSTALLATIONS

- \* Air conditioners
- \* Electric heaters
- \* Solar Panels
- \* Dry wall or false ceilings
- \* Electrical fixtures
- \* Roller shutters or awnings
- \* Ventilation systems
- \* Steel girders
- \* Piping
- \* Barrels and metal drums

## CONSTRUCTION - SIGNWORK

- \* Handling construction materials
- \* Handling pallets
- \* Installations of electric signs
- \* Big screens – Billboards

## MAINTENANCE WORK

- \* Hotels
- \* Airports
- \* Stadiums
- \* Maintenance companies

## STANDS & TRADE FAIRS

- \* Decorating stands
- \* Trade fair set-ups
- \* Conventions and conferences
- \* Big screens and displays
- \* LCD/Plasma screen stand

## MANUAL JOBS

- \* Metalwork
- \* Woodwork
- \* Aluminium framework



[www.guil-lifters.com](http://www.guil-lifters.com)

MADE IN SPAIN



P.I. La Creu C/ Ismael Tomás Alacreu, 28-30  
C.P.46250 L'Alcúdia (VALENCIA) SPAIN

Tel.+34 962996500  
Fax. +34 962540833

info@guil.es  
sales@guil.es



GUIL - YOUR EUROPEAN LIFTING TOWER MANUFACTURER